

TABLE "A" RAFTER SPANS (DOUGLAS FIR #2 OR BETTER)		
SIZE	SPACING	SPAN
2 x 4	12" O.C.	9' - 10"
	16" O.C.	8' - 11"
	24" O.C.	7' - 8"
	32" O.C.	*6' - 3"
2 x 6	12" O.C.	15' - 4"
	16" O.C.	13' - 9"
	24" O.C.	11' - 3"
	32" O.C.	*9' - 7"
2 x 8	12" O.C.	20' - 0"
	16" O.C.	18' - 2"
	24" O.C.	14' - 10"
	32" O.C.	*12' - 8"
2 x 10	12" O.C.	20' - 0"
	16" O.C.	20' - 0"
	24" O.C.	18' - 11"
	32" O.C.	*16' - 2"
4 x 4	24" O.C.	10' - 0"
	32" O.C.	*9' - 3"
	48" O.C.	*7' - 8"
4 x 6	24" O.C.	15' - 11"
	32" O.C.	*13' - 9"
	48" O.C.	*11' - 3"
4 x 8	24" O.C.	20' - 0"
	32" O.C.	*18' - 2"
	48" O.C.	*14' - 10"

TABLE "B" HEADER SIZE & SPANS (DOUGLAS FIR #2 OR BETTER)		
RAFTER SPAN	HEADER	
	SPAN	SIZE
UP TO 12'-0"	8'-0" MAX	4 x 6
	10'-0" MAX	4 x 8
	12'-0" MAX	4 x 10
	14'-0" MAX	4 x 12
12'-1" TO 20'-0"	8'-0" MAX	4 x 8
	10'-0" MAX	4 x 10
	12'-0" MAX	4 x 12
	14'-0" MAX	4 x 14

TABLE "C" FOOTING SIZE
BASED ON 1000 P.S.F. SOIL BEARING PRESSURE.
18" SQ. X 12" DEEP
18" SQ. X 12" DEEP
18" SQ. X 12" DEEP
18" SQ. X 12" DEEP
24" SQ. X 12" DEEP
24" SQ. X 12" DEEP
24" SQ. X 12" DEEP
24" SQ. X 12" DEEP

TABLE "D" LEDGER BOLTING Δ
ALL LAG BOLTS SHALL HAVE 1/4" PRE-DRILLED HOLES - (SEE NOTE 2)
1/2" DIA. X 5" LONG AT 16" O.C. STAGGERED
(2) 3/8" DIA X 5" LONG AT 16" O.C.

NOTES:

- TWO 2X MEMBERS MAY BE SUBSTITUTED FOR ONE 4X HORIZONTAL FRAMING MEMBER.
- LAG BOLTS MUST FULLY ENGAGE A WOOD STUD OR RIM JOIST AND BE PROVIDED WITH APPROPRIATE WASHERS. LAG BOLTS SHALL BE LOCATED A MINIMUM OF 1-1/2" FROM THE TOP OR BOTTOM OF THE LEDGER.
- NOT DESIGNED TO BE ENCLOSED - ADDITIONAL ENGINEERING ANALYSIS WILL BE REQUIRED IF ENCLOSED.
- SEE PAGE 2 OF 2 FOR CONSTRUCTION DETAILS.
- ARTIFICIAL LIGHTING IS REQUIRED IN ROOMS THAT HAVE WINDOW OPENINGS INTO THE COVERED PATIO AREA IF THE TOTAL WINDOW AREA IN THAT ROOM IS LESS THAN 10% OR THE FLOOR AREA OF THE ROOM OR 20 SQUARE FEET, WHICHEVER IS GREATER. Δ

DISCLAIMER:

ALTERNATE PATIO DESIGNS MAY BE POSSIBLE WHEN PROVIDED WITH AN ENGINEERED ANALYSIS. USE OF THIS CONVENTIONAL STANDARD DESIGN IS AT THE USER'S RISK AND CARRIES NO IMPLIED OR INFERRED GUARANTEE AGAINST FAILURE OR DEFECTS.

* THIS SPACING AND SPAN IS FOR LATTICE PATIO COVERINGS ONLY.

WESTERN RIVERSIDE COUNTY CODE UNIFORMITY PROGRAM			
	CITY OF SAN JACINTO BUILDING & SAFETY		
	PATIO COVER STANDARD		
PHONE 951-487-7330		595 S. SAN JACINTO AVENUE SAN JACINTO, CA 92583	
FAX 951-654-9896		1/1/2008 Δ	PATIOSTD2008.VSD
		PAGE 1 OF 2	

KNEE BRACE DETAIL AT END POSTS

(REQUIRED WHEN RAFTER SPAN EXCEEDS 12 FT.)

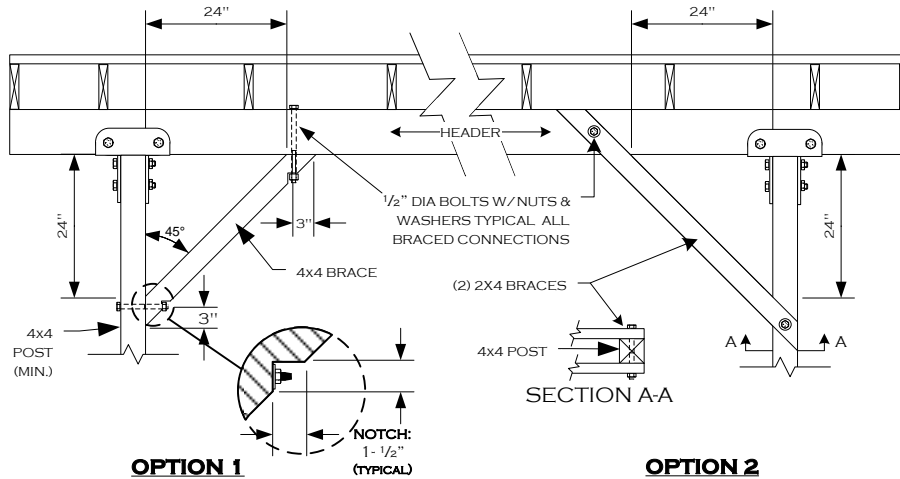

LEDGER ATTACHMENT DETAIL

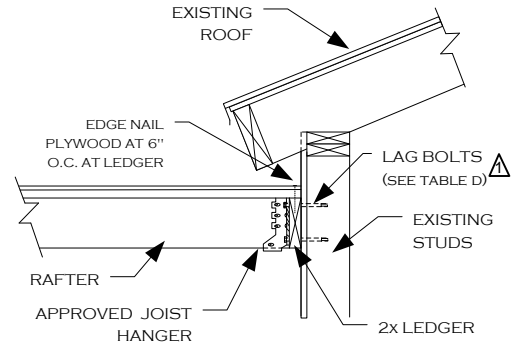

NOTES:

1. USE A CONTINUOUS 2X LEDGER – SAME DEPTH AS RAFTER OR LARGER
2. SEE TABLE "D" FOR BOLTING REQUIREMENTS

INVERTED HEADER DESIGN OPTION (LATTICE ONLY)

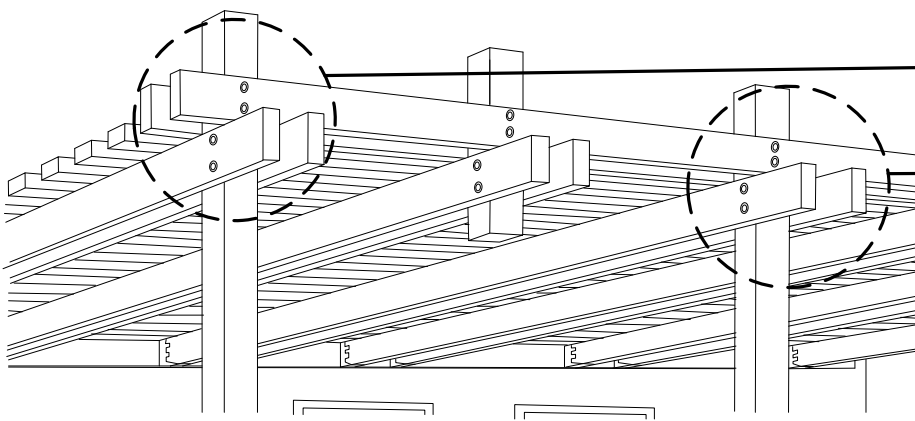

TWO 1/2" DIA. THRU-BOLTS (W/ WASHERS), PER CONNECTION AS SHOWN

FOR HEADERS OR RAFTERS—TWO 2X MEMBERS MAY BE SUBSTITUTED FOR ONE 4X MEMBER. SEE TABLES "A" & "B" FOR SPAN LIMITS

NOTE: KNEE BRACING REQUIRED WHEN RAFTER SPAN EXCEEDS 12 FEET

2X FASCIA (OVERHANG) ATTACHMENT – LATTICE ONLY

OPTION 1

OPTION 2

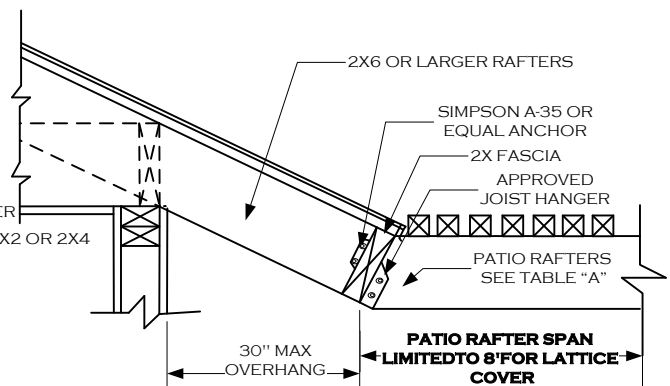
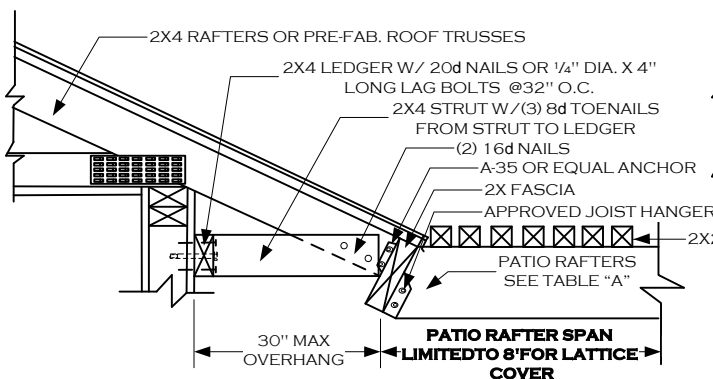

NOTE: VERIFY STRUCTURAL SOUNDNESS OF ROOF RAFTERS FOR DECAY OR TERMITE DAMAGE, AND REPLACE WITH LIKE MATERIALS AS NEEDED, AFTER CONSULTATION WITH THE BUILDING DEPARTMENT.

WESTERN RIVERSIDE COUNTY CODE UNIFORMITY PROGRAM



CITY OF SAN JACINTO BUILDING & SAFETY

PATIO COVER STANDARD

PHONE 951-487-7330

FAX 951-654-9896

595 S. SAN JACINTO AVENUE
SAN JACINTO, CA 92583

1/1/2008

PATIOStd2008.vsd

PAGE 2 OF 2